



ACMA

Agricultural machinery since 1958

Gamma ERPICI ROTANTI



POWER HARROWS Range
Gama GRADAS ROTATIVAS
KREISELEGGEN Reichweite

IT-EN-ES-TE

model E

25-100 HP

- Riduttore mono-velocità
- Barra livellatrice posteriore
- Albero portadenti in acciaio
- Fiancate laterali oscillanti

- Protezioni antinfortunistiche CE
- Parasassi anteriore e parapietre richiesta
- Regolazione rapida rullo posteriore
- Larghezze lavoro da 1 a 2,5 metri

- Single speed gearbox
- Rear levelling bar
- Steel tooth shaft
- Tilting side panel

- CE safety guards
- Front and rear stone guard required
- Rear roller quick adjustment
- Working widths from 1 to 2.5 meters









- Reductor de velocidad simple
- Barra de nivelación trasera
- Eje del diente de acero
- Vial lateral oscilante

- Guardias de seguridad CE
- Se requieren barandillas delanteras y de piedra
- Ajuste rápido del rodillo trasero
- Anchuras de trabajo desde 1 hasta 2,5 metros

- Ein Geschwindigkeitsreduzierer
- Stahlzahnwelle
- Riduttore mono-velocità
- Oszillierende Seitenfläschchen

- CE-Schutzvorrichtungen
- Vorderer und hinterer Steinschutz erforderlich
- Hintere Rollenschnelleinstellung
- Arbeitsbreiten von 1 bis 2,5 Metern



MODEL	 cm	 HP	 540 g/min 1000		 n°	 cm	 Kg	 Kg	 Kg
E100L	100	25-35	279	518	4	23	370	380	
E125L	125	35-45	279	518	5	23	420	440	
E150L	150	40-45	279	518	6	23	480	500	
E180L	180	45-50	279	518	7	25	510	525	610
E200L	200	50-60	279	518	8	25	540	550	680
E225L	225	60-70	279	518	9	25	560	570	740
E250L	250	70-100	279	518	10	25	580	580	800

model R





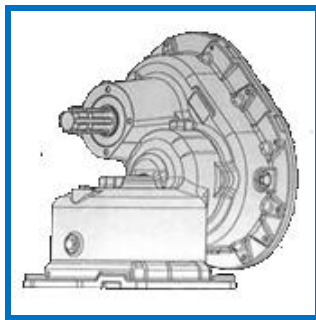



60-160 HP

- Barra livellatrice posteriore
- Parasassi anteriore e parapietre richiesta
- Rear levelling bar
- Front and rear stone guard required
- Barra de nivelación trasera
- Se requieren barandillas delanteras y de piedra
- Stahlzahnwelle
- Vorderer und hintere Steinschutz erforderlich
- Fiancate laterali oscillanti
- Larghezze di lavoro da 2,25 a 3 metri
- Tilting side panel
- Working widths from 2,25 to 3 meters
- Vial lateral oscillante
- Anchuras de trabajo desde 2,25 hasta 3 metros
- Hintere Rollenschnelleinstellung
- Arbeitsbreiten von 2,25 bis 3 Metern



Cambio di velocità
Speed change
Cambio de velocidad
Geschwindigkeitsänderung



MODEL	 cm	 HP	 540 g/min 1000		 n°	 cm	 Kg	 Kg	 Kg
R225S	225	60-90	221	305	9	25	750	760	880
R250S	250	70-130	221	305	10	25	800	820	950
R300S	300	100-160	221	305	12	25	890	900	1050

model S









100-220 HP

- Barra livellatrice posteriore
- Parasassi anteriore e parapietre richiesta
- Rear levelling bar
- Front and rear stone guard required
- Barra de nivelación trasera
- Se requieren barandillas delanteras y de piedra
- Stahlzahnwelle
- Vorderer und hintere Steinschutz erforderlich
- Fiancate laterali oscillanti, cambio di velocità
- Larghezze di lavoro da 2,50 a 4 metri
- Tilting side panel, speed change
- Working widths from 2,50 to 4 meters
- Vial laterale oscillante, cambio de velocidad
- Anchuras de trabajo desde 2,50 hasta 4 metros
- Hintere Rollenschnelleinstellung, Geschwindigkeit
- Arbeitsbreiten von 2,50 bis 4 Metern

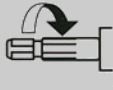

- BANDELLA LATERALE e PARAPIETRE
- SIDE PANEL and STONE GUARD
- VIAL LATERAL y PIEDRA PROTECTION
- ROLLENSCHNELLEINSTELLUNG



MODEL	 cm	 HP	 540 g/min 1000		 n°	 cm	 Kg	 Kg	 Kg
S250M	250	100-130	221/305	410	10	27	870	890	1050
S300M	300	120-160	221/305	410	12	27	1000	1030	1310
S350M	350	140-200	221/305	410	14	27	1120	1140	1420
S400M	400	160-220	221/305	410	16	27	1220	1250	1600

model K

130-260 HP









- Barra livellatrice posteriore
- Parasassi anteriore e parapietre richiesta
- Rear levelling bar
- Front and rear stone guard required
- Barra de nivelación trasera
- Se requieren barandillas delanteras y de piedra
- Stahlzahnwelle
- Vorderer und hintere Steinschutz erforderlich
- Fiancate laterali oscillanti, cambio di velocità
- Larghezze di lavoro da 3 a 4 metri
- Tilting side panel, speed change
- Working widths from 3 to 4 meters
- Vial lateral oscillante, cambio de velocidad
- Anchuras de trabajo desde 3 hasta 4 metros
- Hintere Rollenschnelleinstellung, Geschwindigkeit
- Arbeitsbreiten von 3 bis 4 Metern

A RICHIESTA - ON REQUEST A PEDIDO - AUF ANFRAGE



Sgancio rapido coltelli
Quick release knives
Cuchillos de liberacion rapida
Schnellmesser



MODEL	 cm	 HP	 540 g/min 1000	 n°	 cm	 Kg	 Kg	 Kg	
K300I	300	130-200	170/370	315	12	28	1200	1200	1400
K350I	350	150-230	170/370	315	14	28	1360	1400	1620
K400I	400	160-260	170/370	315	16	28	1580	1600	1890







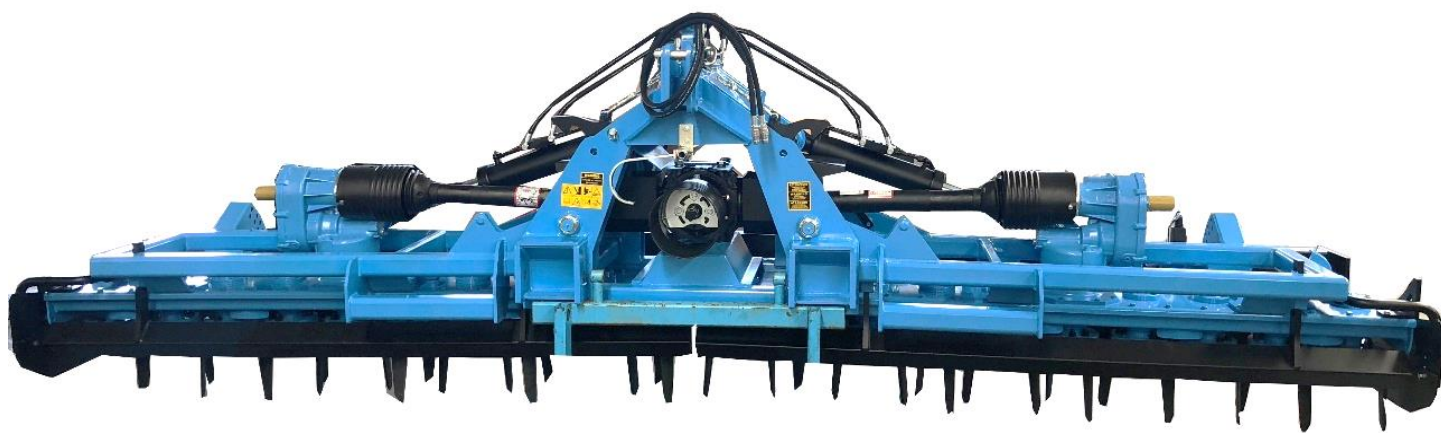

model AR – AS – AK

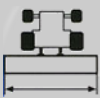
140-320 HP

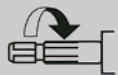
- Barra livellatrice posteriore
- Parasassi anteriore e parapietre richiesta
- Rear levelling bar
- Front and rear stone guard required
- Barra de nivelación trasera
- Se requieren barandillas delanteras y de piedra
- Stahlzahnwelle
- Vorderer und hintere Steinschutz erforderlich
- Fiancate laterali oscillanti
- Larghezze di lavoro da 4 a 6 metri
- Tilting side panel
- Working widths from 4 to 6 meters
- Vial lateral oscillante
- Anchuras de trabajo desde 4 hasta 6 metros
- Hintere Rollenschnelleinstellung
- Arbeitsbreiten von 4 bis 6 Metern



model AR

MODEL	 cm	 HP	 540 g/min 1000	 n°	 cm	 Kg	 Kg	 Kg	
AR400	400	140-160	221/305	410	16	25	2220	2250	2400
AR500	500	150-200	221/305	410	20	25	2420	2450	2580
AR600	600	180-260	221/305	410	24	25	2630	2650	2800

model AS

AS400	400	150-180	221/305	410	16	27	2420	2450	2600
AS500	500	160-230	221/305	410	20	27	2620	2650	2780
AS600	600	180-300	221/305	410	24	27	2830	2850	3000

model AK

AK400	400	150-200	221/305	410	16	28	2540	2550	2700
AK500	500	160-250	221/305	410	20	28	2740	2750	2900
AK600	600	180-320	221/305	410	24	28	2940	2950	3150

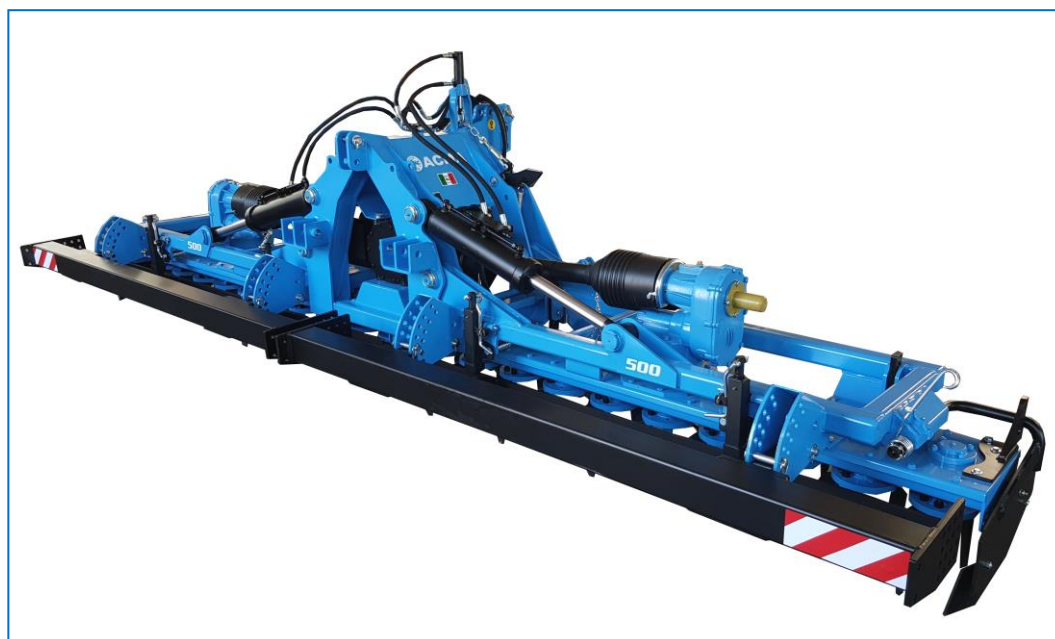

Rulli-rollers



Rullo gabbia

Cage roller – Rodillo de barras - Stabwalze



Rullo packer

Packer roller – Rodillo packer - Packerwalze



Rullo spuntoni

Spike roller – Rodillo con puntas - Zinkenwalze



Seminatrici - Seed drills - Sembradoras

